

The patient's bed head luminaire

The new Luxo Carelite

With
LED light
source



The patient's bed head luminaire

The new Carelite is a natural development of our original patient's bed head luminaire, which can be found in hospital wards and patient rooms all over the world.

It is the use of modern LED light sources that has made it possible to reduce the size of the new lamp head, compared with the original. Still, the integrated ergonomic handle remains an important feature, enabling the patient to direct the light exactly where he or she wants it, with minimal effort. The switch is positioned exactly where the thumb will find it when the hand grabs the handle. This makes operation easy even for patients with disabilities. Carelite is fully dimmable.

Exact positioning

Carelite has a covered spring balanced arm for easy cleaning and safe and easy positioning. The flexibility and precision of the spring balanced arm means that Carelite can be positioned exactly where the light is required. The light sources are positioned well inside the

lamp head, in order to avoid glare. This is particularly important in multi-bed wards, as it allows one patient to have his or her reading light on without disturbing other patients in the ward.

All-metal construction

Carelite is made of powder-coated metal, such as aluminium and steel. This means that Carelite can be cleaned with any detergent in use at a hospital, including acetone.

Easy replacement

The new Carelite features the same arm construction and spigot as the traditional version. This means that all brackets and clamps can be reused with this new version.



Integrated night light

The switch is positioned exactly where the thumb will find it when the hand grabs the handle. Carelite is also equipped with a night light, just enough for the nurse to check on the patient.



Design: Aleksander Borgenhov

Aleksander Borgenhov is one of Norway's most award winning industrial designers. His work has resulted in a wide range of successful products, including furniture, lighting, commercial goods, sports equipment, health & medical, marine & offshore. He has designed several of our most recent luminaires, including a complete series of illuminated magnifiers and a task light.

LED – light source of the future

With the introduction of LED, the international lighting industry has gained a new light source that is more energy efficient than fluorescent tubes and other conventional light sources. The efficiency and life span of LED continues to improve, and LED luminaires are virtually maintenance free.

Our LED luminaires have long duration and low energy consumption since we only use the very best LED components, which are tested in our own laboratories. Equally important is our experience and know-how about the design of optics and thermal control, so that the luminaires will perform to standard over a long period of time.

Extremely energy efficient

Light emitting diodes are not only small and robust. Carelite's LEDs are extremely energy efficient, and have an incredible life span of 50 000 hours or more. The powerful LED module has an excellent light output giving approximately 2000 lux @ 0.6 metres.



Arms for wall
mounting always tilt forward, and are designed for maximum vertical movement.

Perfect balance

Medical products are used in a dynamic environment and need a great level of flexibility. Luxo pioneered self-balancing arms more than 75 years ago, and we have constantly improved them ever since. Intricate internal spring systems ensure smooth and easy positioning. Carelite's arm will always stay in the right position without drifting.

The ability to place the light exactly where it is needed is a hallmark of our spring balanced arms. These arms have a virtually maintenance free construction, and are easy to install.



Protected by SteriTouch®

Carelite is painted with SteriTouch® antimicrobial powder coating, which prevents the growth of bacteria, biofilm and mould. Based on ionic silver technology, the antimicrobial performance remains continuously effective throughout the product's lifetime.

SteriTouch® is a leading brand in established and proven antimicrobial technology, holding numerous approvals. Laboratory testing has been carried out independently to international standards, demonstrating over 99% efficacy against MRSA and E. coli over 24 hours.

SteriTouch® represents an excellent additional measure to routine cleaning, providing a permanent and invisible barrier to pathogens.

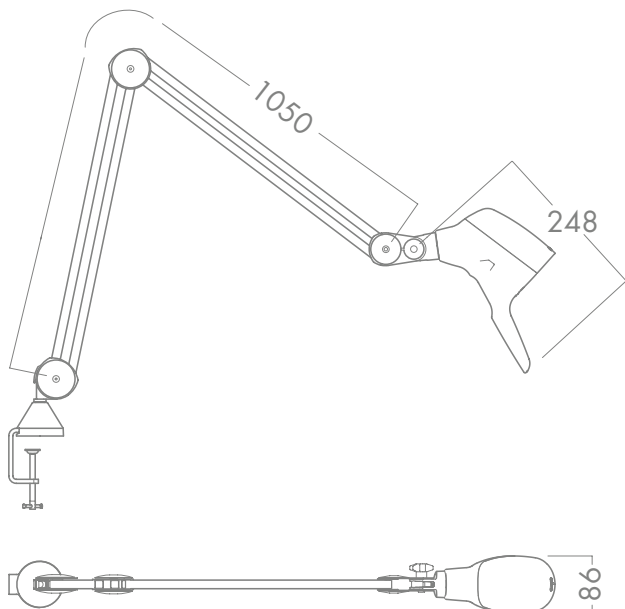

Light source: LED
 Colour rendering: CRI >95
 Lifetime: Minimum 50 000 hours
 CCT: 3000 K
 Lux @ 0.6 metres: Approx. 2000 lux
 Lumen out: 400lm
 Switch: On/off and seamless dimming
 Night light: Starts at 1% light
 Colour: White

Selection of items

Article no.	Type
CAG026487	Carelite G2 W105 Wh 108 930 EU
CAG026488	Carelite G2 W115 Wh 108 930 EU
CAG026489	Carelite G2 T105 Wh 108 930 EU

Please see our web for more variants and details



Options and accessories

Carelite is offered with two different arm lengths for wall mounting. We offer a wide choice of brackets and mounts for this purpose. Please refer to our web site and make sure to order the correct option for your application. A table/trolley version of Carelite is also available.

LED technology
 The LED technology is in rapid development, and we are upgrading our LED solutions on a continuous basis. Please refer to our web site for the latest updates on the LED technology featured in this product.